

RITMO AMERICA



"AT EASE IN YOUR JOBSITE"

www.ritmoamerica.com





RITMO S.P.A. is a world leader with over 35 years of experience in the manufacturing of plastic welding equipment. All products are designed and built according to International standards and directives (UNI, ISO, CEE). Since the very beginning, quality and technology innovation are RITMO's milestones, and time after time, this philosophy is always more recognized by the global market. RITMO strong points are its ideas to design and produce accurate, fast, versatile, modular and easy-to-use welding machines. Products range includes butt fusion, electrofusion and extrusion equipment. Ritmo is also providing a complete line of accessories and useful instruments for pipe cutting and weld preparation such as the band saws. RITMO's regards towards the client has brought to the new-born "RITMO FUSION OPERATOR SCHOOL", which is a welding school with the goal of building qualified personnel and spread the knowledge about the technical potentiality of RITMO's equipment: **TECHNOLOGY MADE IN ITALY.**

MADE IN ITALY

**DESIGNED & MANUFACTURED
IN ITALY**



watch the video



**ISO 9001
Quality System**

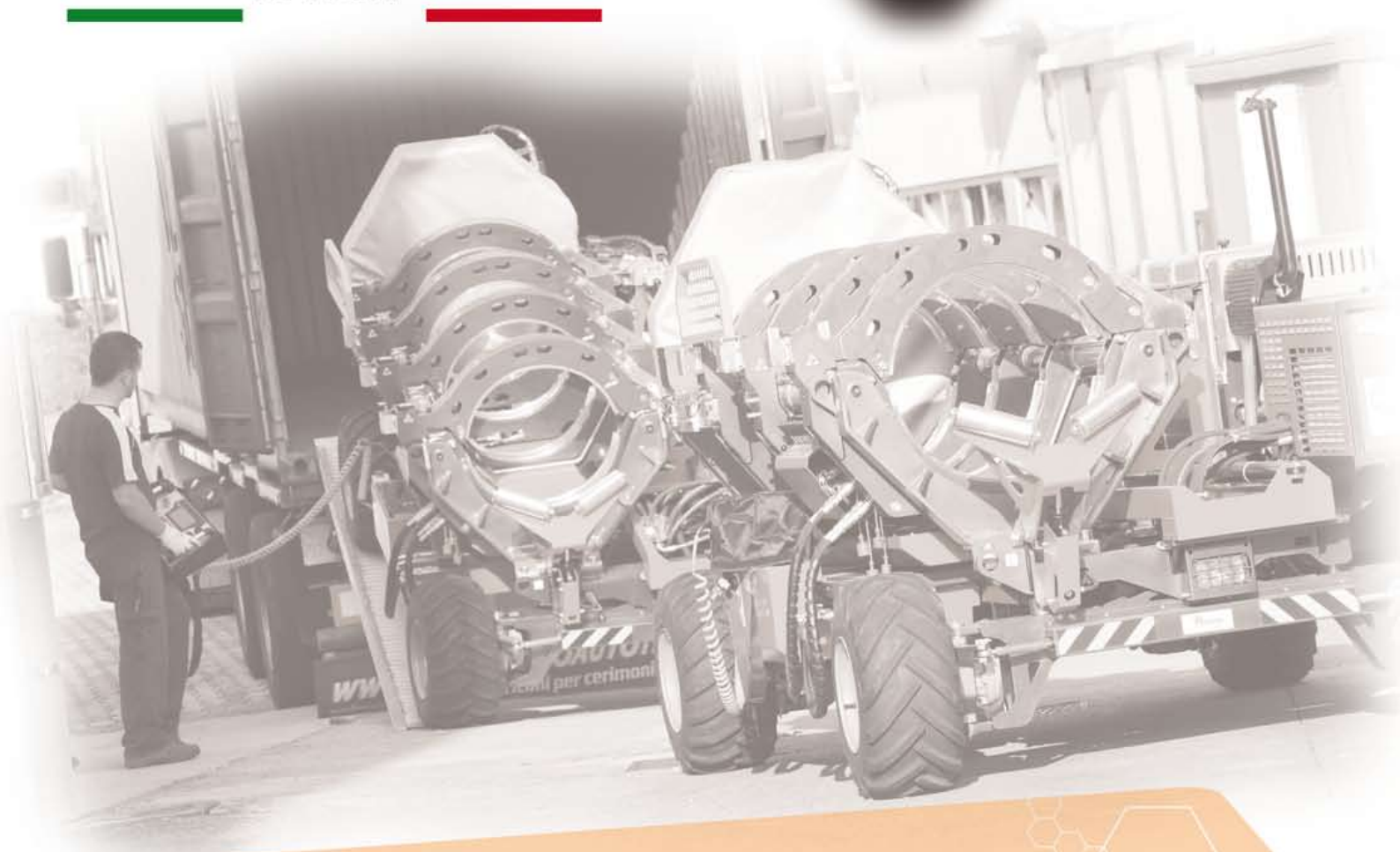



Ritmo America LLC - FL

RITMO

AMERICA

www.ritmoamerica.com



Rossella Contiero - Managing Director



Follow RITMO on



www.youtube.com/user/RitmoPlasticWelding

A

D V A N T A G E

RITMO SERVICE

RITMO WORLDWIDE

Ritmo has professional distributors and resellers all over the world. Our staff is ready to assist you in English, Spanish, French, German, Arab, Italian, Russian and Portuguese.

TRAINING

From many years now, we have decided that the best way to grant a client/distributor a perfect knowledge of our products is to invest in custom training, in our own premises. These courses are aimed to teach how to operate the products in the best way, and how to supply the "first aid" when necessary.

PRESALES TECHNICAL ASSISTANCE

When a client or a potential client wants to buy us a product, it is our standard procedure to help find the best solution to its needs.

GLOBAL ADVICE

In such a technical field as ours, the customer requires the best assistance. Thanks to the experience developed along the years, and to the co-operation with several manufacturers, institutions, schools and training institutes, RITMO is able to give the most comprehensive advice to no matter which related issue.

Our company is a long-time member of a UNIPLAST's (UNI-Italian National Plastics Standards Body) working group dedicated to the study and draw up of new standards within our field. The importance of this group is linked to the fact that the expansion of the plastic welding field ought to be followed by a crescent sensitivity for safety issues, so to have a sustainable and continuous growth. The working group prepares draws, hence present them to the UNI to be discussed and eventually transformed into new standards.

AFTER SALES TECHNICAL ASSISTANCE

Ritmo's Service Centre can solve all kind of technical issues, as well as overhaul our machines. Ritmo has other Service Centres abroad, linked to its official distributors.

STARTING AND TESTING

RITMO' technicians are prepared to make the starting and testing of workshop machines at the client' own premises, so that the fittings production can start almost immediately.

BUTT FUSION MACHINES



WORKING RANGE

MODEL	IPS	DIPS	1	1¼	1½	2	3	4	5	6	8	10	12	14	16	18	20	22	24	26	28	30	32	34	36	40	42	48	54	60	63							
	DELTA 160 M																																					
BASIC 160 EASY LIFE																																						
DELTA DRAGON 160																																						
BASIC 200 EASY LIFE																																						
DELTA DRAGON 250 B																																						
DELTA 250 TRAILER																																						
BASIC 315 EASY LIFE																																						
DELTA 355 ALL TERRAIN																																						
DELTA 355 TRAILER																																						
BASIC 355 EASY LIFE																																						
DELTA DRAGON 355 B																																						
COMPACT 355 L																																						
DELTA 500																																						
DELTA 500 EASY LIFE																																						
DELTA 500 ALL TERRAIN																																						
DELTA 500 TRAILER																																						
DELTA 630 TRAILER																																						
DELTA 630 ALL TERRAIN																																						
DELTA 630																																						
DELTA 630 EASY LIFE																																						
DELTA 800																																						
DELTA 1000 TRAILER																																						
DELTA 1000																																						
DELTA 1200																																						
DELTA 1600																																						

● On request



DELTA 630 ALL TERRAIN



watch the video

The **DELTA 630 ALL TERRAIN** is the pipe and fittings fusion machine designed to face the toughest working conditions. Built according to the International standards **ISO 21307 HIGH PRESSURE** (the clamps cylinders work with a pressure range that is three times and a half higher than the ISO Low Pressure ones. This enhances productivity, with a welding time saving of 60%). **The machine is equipped with a 2200 cc diesel ENGINE** which powers the **4-wheels DRIVE traction** and the generator, assuring a totally independent and autonomous Fusion Machine. Its detachable control panel allows an intuitive **CONTROL** of the 4 steering wheels; besides making **DELTA 630 ALL TERRAIN** movements a lot easier, it also grants a fast and perfect alignment of the pipes. Machine's hydraulic operations significantly reduce time and operational costs.

DELTA 630 ALL TERRAIN is also trench-friendly: **CHASSIS** can be **REMOVED** from the trolley and top-load the Heating Plate and Facer. Machine includes Ritmo's most successful "**Easy Life**" Fusion System which helps the operator to program and manage the fusion in a simple and precise manner. The Easy Life system can store up to 400 joint reports. A **GPS System**, a large display and Data-Logging complete the features of this exceptional Fusion Machine.

DELTA 630 ALL TERRAIN wants to mark a turning point to the world of Field Fusion. It stands out for being extremely easy to set up and work with. Take the heating plate and facer disconnecting system for example; the positioning / removal of the pipes is made without obstacles, giving the operator more time for what really matters. Italian design, known for paying particular attention to details, gives **DELTA 630 ALL TERRAIN** many technical innovations that are indeed practical. Take the clamps hydraulic system, for instance - not only an aesthetical maneuver, but a protection against collisions while positioning the machine inside the trench. Take the low fuel consumption and soundproofing gear – protects the environment, your health and saves your money!



TECHNICAL FEATURES

Working range	8" IPS ÷ 24" DIPS (225 ÷ 630 mm)
Engine	2200 cc - 22,7 Kw
Fuel type	Diesel
Fuel tank capacity	10,5 Gallons
Operational tank capacity	12 Hours
Hydraulics reservoir capacity	21 Gallons
Materials	HDPE, PP For other materials contact RITMO S.P.A.
DIMENSION (W x D x H)	
Machine body	86,6" x 122" x 78,7"
WEIGHT	
Machine body	1760 lb
Standard composition	6600 lb

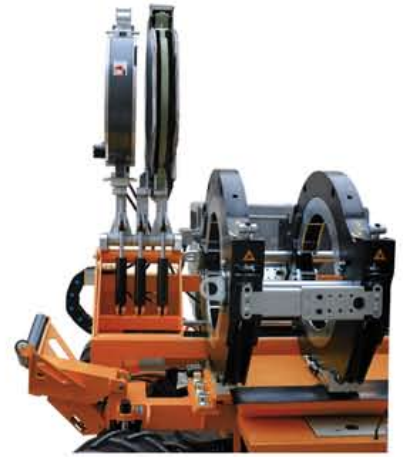

heating plate/facer disconnecting system

ON REQUEST (ACCESSORIES)

- Clamps' inserts from
Ø 8" IPS to 24" IPS
Ø 8" DIPS to 20" DIPS
Ø 225 to 630 mm
- Tool for flange necks
- Kit for IN-DITCH use
- Kit hoist
- Kit printer
- Kit exhaust fumes
- HS ROLLERS 63
- Panel with manual control

- *4 steering wheels drive*
- *Diesel-engine*
- *Self-contained with on-board generator*
- *Sliding 3rd CLAMP for fittings welding*
- *Automatic welding Systems "Easy Life"*
- *Detachable Control Panel*
- *Remotely wire-controlled up to 39 ft*
- *Trench-Friendly*
- *Adjustable Speed maximum 5 Km/h*
- *Climbs rough terrain up to 30%*



USA



HS ROLLERS

HIGH STAND ROLLERS, this device is essential for supporting the pipes while they are being welded with the butt fusion machines. The rollers minimise pipe friction and drag force no matter which is the construction site condition. Special design for All Terrain / Trailer Line.



HS ROLLERS 250

Working range max: Ø 8" (250 mm)
Overall dimension: 45" x 20" x 30" (W x D x H)
Weight: 57 lb
Weight capacity: 1100 lb

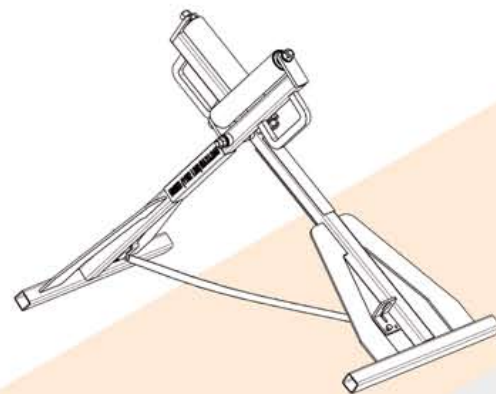
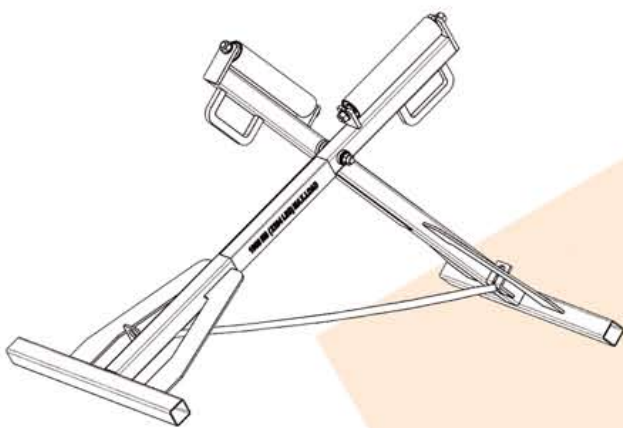

HS ROLLERS 355

Working range max: Ø 14" (355 mm)
Overall dimension: 56" x 23,5 x 32" (W x D x H)
Weight: 72,5 lb
Weight capacity: 2200 lb

HS ROLLERS 630

Working range max: Ø 24" (630 mm)
Overall dimension: 69,5" x 31,5" x 38,5" (W x D x H)
Weight: 121 lb
Weight capacity: 4400 lb

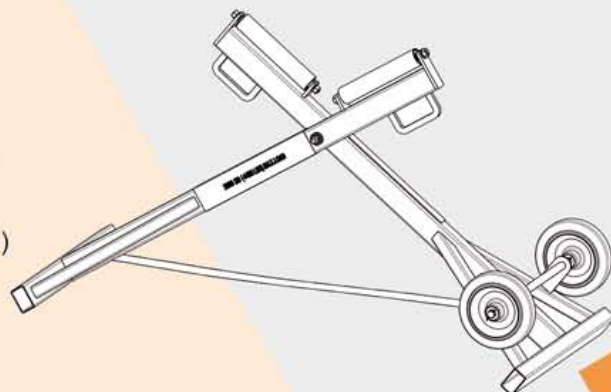

DOWNLOAD

SET & GO!

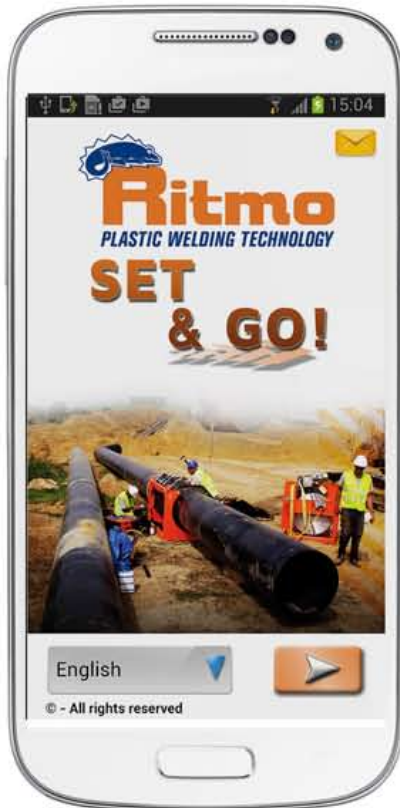

APP developed by RITMO for its butt fusion machines.

“SET & GO” calculates the welding parameters in a simple, fast and useful way.

Through easy steps, like selecting the machine model, setting up the pipe data and choosing the welding standard, “SET & GO” tells you immediately your welding parameters!

The welding cycle is assisted and guided, step-by-step, by a handy timer with countdown function

“SET & GO” ...set to the future!



BUTT FUSION MACHINES REFERENCE

MODEL	32	40	50	56	63	75	90	110	125	140	160	180	200	225	250	280	315	355	400	450	500	560	630	710	800	900	1000	1200	1400	1600	
Millimeters	32	40	50	56	63	75	90	110	125	140	160	180	200	225	250	280	315	355	400	450	500	560	630	710	800	900	1000	1200	1400	1600	
DELTA 160 M																															
BASIC 160 EASY LIFE																															
DELTA DRAGON 160																															
BASIC 200 EASY LIFE																															
DELTA DRAGON 250 B																															
DELTA 250 TRAILER																															
BASIC 315 EASY LIFE																															
DELTA 355 ALL TERRAIN																															
DELTA 355 TRAILER																															
BASIC 355 EASY LIFE																															
DELTA DRAGON 355 B																															
COMPACT 355 L																															
DELTA 500																															
DELTA 500 EASY LIFE																															
DELTA 500 ALL TERRAIN																															
DELTA 500 TRAILER																															
DELTA 630 TRAILER																															
DELTA 630 ALL TERRAIN																															
DELTA 630																															
DELTA 630 EASY LIFE																															
DELTA 800																															
DELTA 1000 TRAILER																															
DELTA 1000																															
DELTA 1200																															
DELTA 1600																															
Millimeters	32	40	50	56	63	75	90	110	125	140	160	180	200	225	250	280	315	355	400	450	500	560	630	710	800	900	1000	1200	1400	1600	





RITMO AMERICA LLC

300 Acuff Road - Lake Wales FL 33859
Phone 863-679-8655 Fax 863-679-8685
www.ritmoamerica.com - info@ritmoamerica.com



RITMO S.p.A.

Via A. Volta, 35/37 - 35037 Bressio di Teolo (PADOVA) ITALY
Ph. +39 049 9901888 Fax +39 049 9901993
info@ritmo.it - www.ritmo.it



Watch
the Corporate Video