

RITMO AMERICA



"AT EASE IN YOUR JOBSITE"

www.ritmoamerica.com





RITMO S.P.A. is a world leader with over 35 years of experience in the manufacturing of plastic welding equipment. All products are designed and built according to International standards and directives (UNI, ISO, CEE). Since the very beginning, quality and technology innovation are RITMO's milestones, and time after time, this philosophy is always more recognized by the global market. RITMO strong points are its ideas to design and produce accurate, fast, versatile, modular and easy-to-use welding machines. Products range includes butt fusion, electrofusion and extrusion equipment. Ritmo is also providing a complete line of accessories and useful instruments for pipe cutting and weld preparation such as the band saws. RITMO's regards towards the client has brought to the new-born "RITMO FUSION OPERATOR SCHOOL", which is a welding school with the goal of building qualified personnel and spread the knowledge about the technical potentiality of RITMO's equipment: **TECHNOLOGY MADE IN ITALY.**

MADE IN ITALY

**DESIGNED & MANUFACTURED
IN ITALY**



watch the video



**ISO 9001
Quality System**





Ritmo America LLC - FL

RITMO AMERICA

www.ritmoamerica.com



Rossella Contiero - Managing Director



Follow RITMO on



www.youtube.com/user/RitmoPlasticWelding

A

D V A N T A G E

RITMO SERVICE

RITMO WORLDWIDE

Ritmo has professional distributors and resellers all over the world. Our staff is ready to assist you in English, Spanish, French, German, Arab, Italian, Russian and Portuguese.

TRAINING

From many years now, we have decided that the best way to grant a client/distributor a perfect knowledge of our products is to invest in custom training, in our own premises. These courses are aimed to teach how to operate the products in the best way, and how to supply the "first aid" when necessary.

PRESALES TECHNICAL ASSISTANCE

When a client or a potential client wants to buy us a product, it is our standard procedure to help find the best solution to its needs.

GLOBAL ADVICE

In such a technical field as ours, the customer requires the best assistance. Thanks to the experience developed along the years, and to the co-operation with several manufacturers, institutions, schools and training institutes, RITMO is able to give the most comprehensive advice to no matter which related issue.

Our company is a long-time member of a UNIPLAST's (UNI-Italian National Plastics Standards Body) working group dedicated to the study and draw up of new standards within our field. The importance of this group is linked to the fact that the expansion of the plastic welding field ought to be followed by a crescent sensitivity for safety issues, so to have a sustainable and continuous growth. The working group prepares draws, hence present them to the UNI to be discussed and eventually transformed into new standards.

AFTER SALES TECHNICAL ASSISTANCE

Ritmo's Service Centre can solve all kind of technical issues, as well as overhaul our machines. Ritmo has other Service Centres abroad, linked to its official distributors.

STARTING AND TESTING

RITMO' technicians are prepared to make the starting and testing of workshop machines at the client' own premises, so that the fittings production can start almost immediately.

FITTINGS FABRICATION MACHINES

EGYPT



WORKING RANGE Ø

MODEL	IPS	DIPS	2	3	4	5	6	8	10	12	14	16	18	20	22	24	26	28	30	32	34	36	40	42	48	54	60	63	
	PROFITTINGS 6																												
Elbows																													
Y - T - X																													
ECOFITTINGS 12																													
Elbows																													
Y - T - X																													
PROFITTINGS 14																													
Elbows																													
Y - T - X																													
PROFITTINGS 24																													
Elbows																													
Y - T - X																													
ALFA 1000																													
Elbows																													
Y - T - X																													
ALFA 1200																													
Elbows																													
Y - T - X																													
ALFA 1600																													
Elbows																													
Y - T - X																													
IPS	DIPS	2	3	4	5	6	8	10	12	14	16	18	20	22	24	26	28	30	32	34	36	40	42	48	54	60	63		



ALFA 1200







watch the video

Workshop welding machine designed to fabricate fittings like elbows up to Ø 42" DIPS, wyes, tees and crosses up to Ø 36" DIPS.

The **ALFA 1200** welding plastic materials such as: HDPE, PP.*

STANDARD COMPOSITION:

- **A machine body** with two hydraulically controlled carriages
- **A control panel** that features the CNC system, thanks to this would eliminate any risk of error due to the operator. The CNC incorporates a data-logging that can store up to 4000 cycles. It is possible to download the data via USB slot
- **A Facer** with hydraulic movement (in/out)
- **A Teflon-coated heating plate** with hydraulic movement (in/out)

ELBOWS		24" IPS + 42" DIPS 0 + 60°
WYES (Y)		24" IPS + 36" DIPS 45° + 60°
TEES		24" IPS + 36" DIPS
CROSSES		24" IPS + 36" DIPS
Materials	HDPE, PP <small>*for other plastic materials contact RITMO spa</small>	

WORKING RANGE: Ø 30" IPS ÷ 63" IPS (800 ÷ 1600 mm)





ALFA 1600



Workshop welding machine designed to fabricate fittings like elbows Ø 63" IPS wyes, tees and crosses up to Ø 42" DIPS. The ALFA 1600 welding plastic materials such as: HDPE, PP.*

STANDARD COMPOSITION:

- **A machine body** with two hydraulically controlled carriages
- **A control panel** that features the CNC system, thanks to this would eliminate any risk of error due to the operator. The CNC incorporates a data-logging that can store up to 4000 cycles. It is possible to download the data via USB slot
- **A Facer** with hydraulic movement (in/out)
- **A Teflon-coated heating plate** with hydraulic movement (in/out)

ELBOWS		30" IPS + 63" IPS 0 + 60°
WYES (Y)		30" IPS + 42" DIPS 45° + 60°
TEES		30" IPS + 42" DIPS
CROSSES		30" IPS + 42" DIPS
Materials	HDPE, PP <small>*for other plastic materials contact RITMO spa</small>	

HOW TO FABRICATE A SPECIAL FITTING

ELBOWS

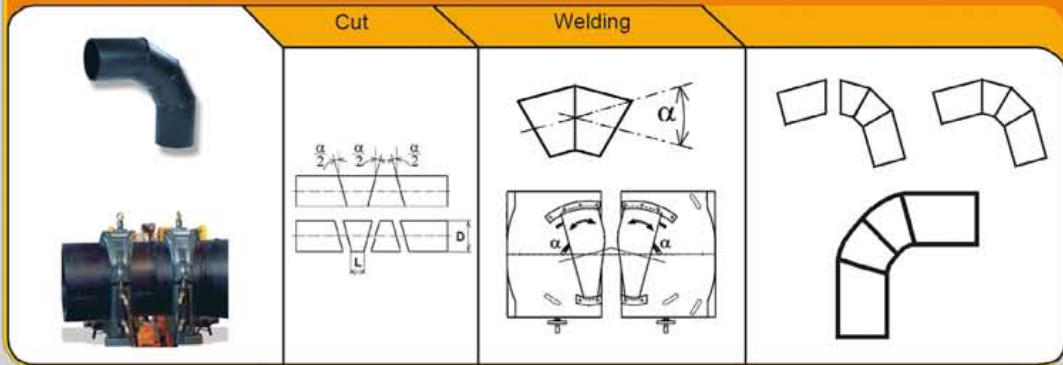

WYES (Y)

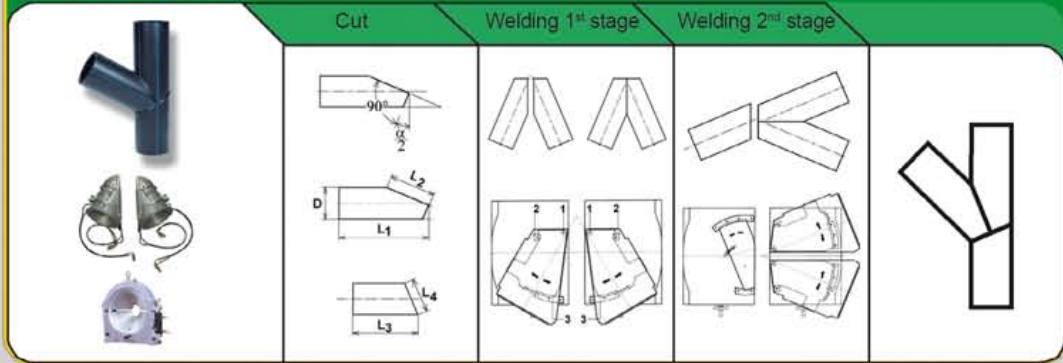

TEES

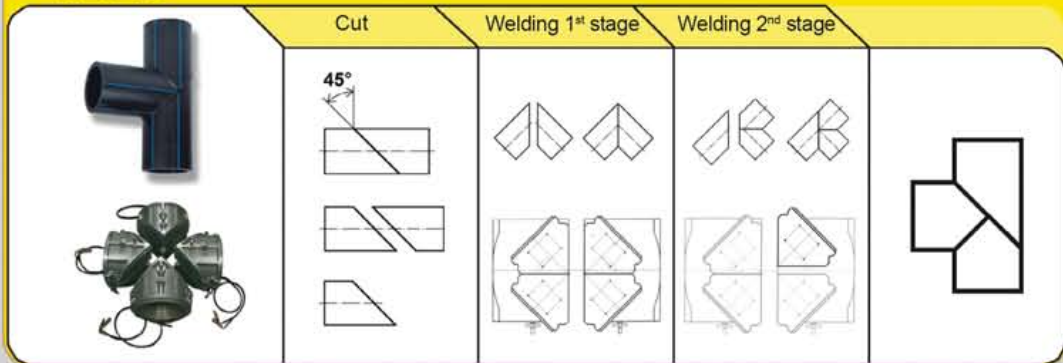

CROSSES

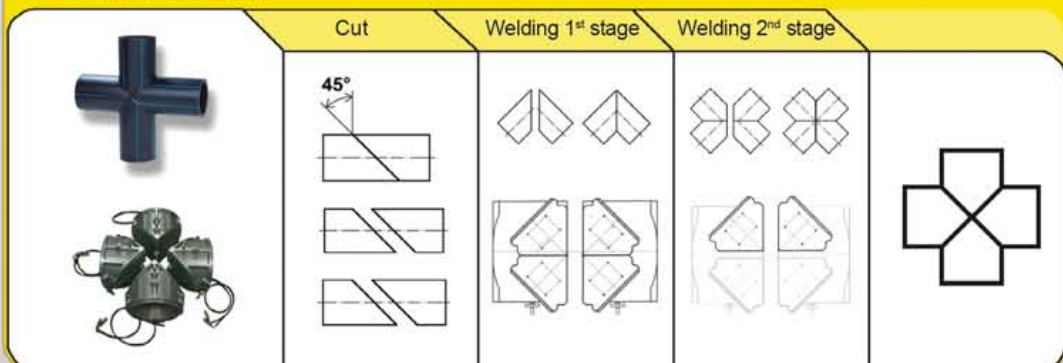



RITMO AMERICA LLC

300 Acuff Road - Lake Wales FL 33859
Phone 863-679-8655 Fax 863-679-8685
www.ritmoamerica.com - info@ritmoamerica.com



RITMO S.p.A.

Via A. Volta, 35/37 - 35037 Bressio di Teolo (PADOVA) ITALY
Ph. +39 049 9901888 Fax +39 049 9901993
info@ritmo.it - www.ritmo.it



Watch
the Corporate Video